

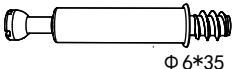

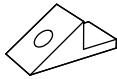







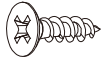

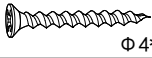
PARTS LIST

NO.	ITEM	QTY	NO.	ITEM	QTY
A	 Φ 6*35	50PCS	I		14PCS
B	 Φ 15*10	64PCS	J	 Φ 3*16	14PCS
C	 Φ 6*30	20PCS	K	 CL	6PCS
D	 Φ 4*35	40PCS		 DL	
E	 Φ 4*35	2PCS		 CR	
F	 Φ 2.5*12	6PCS		 DR	
G		2PCS	L		7PCS
H	 Φ 3*12	72PCS	M	 Φ 6*50	5PCS

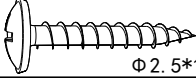
STEP 1:

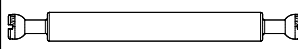

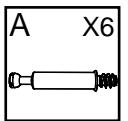
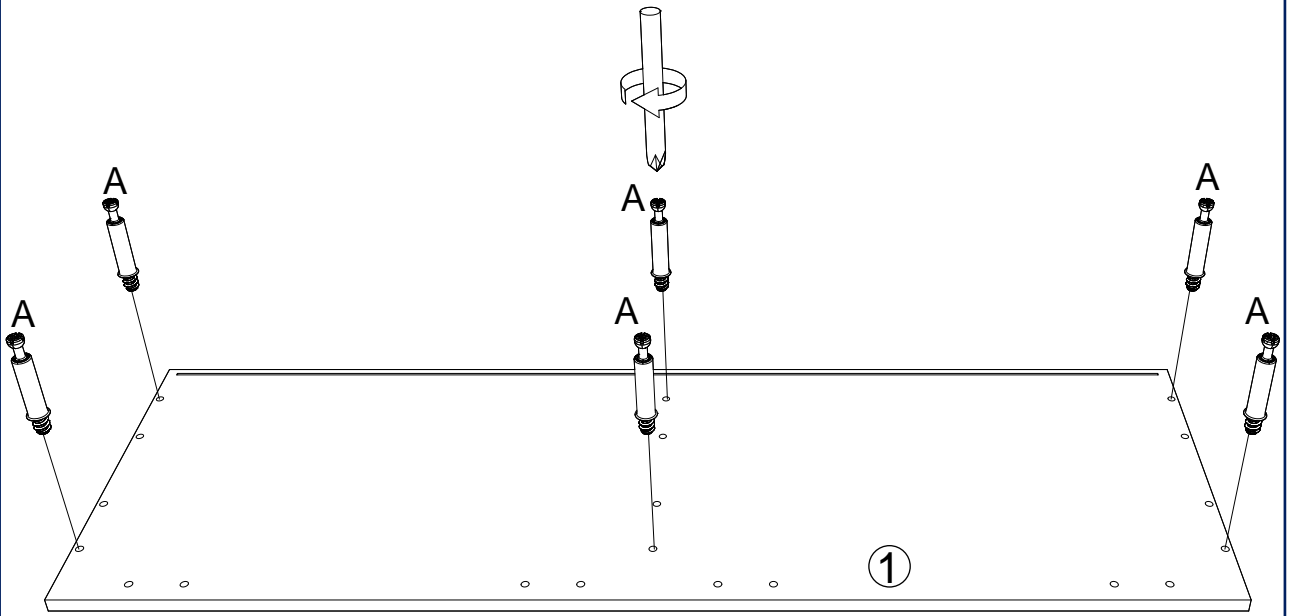
STEP 2:

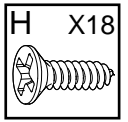
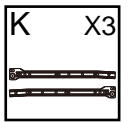
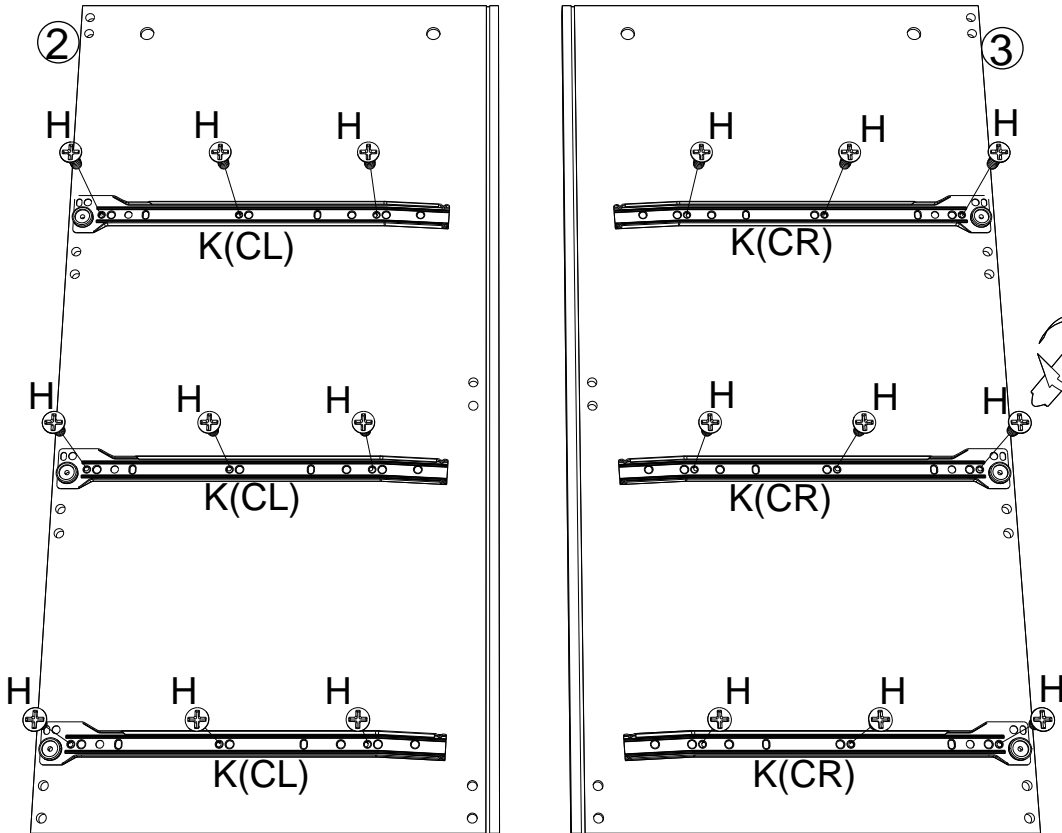

STEP 3:

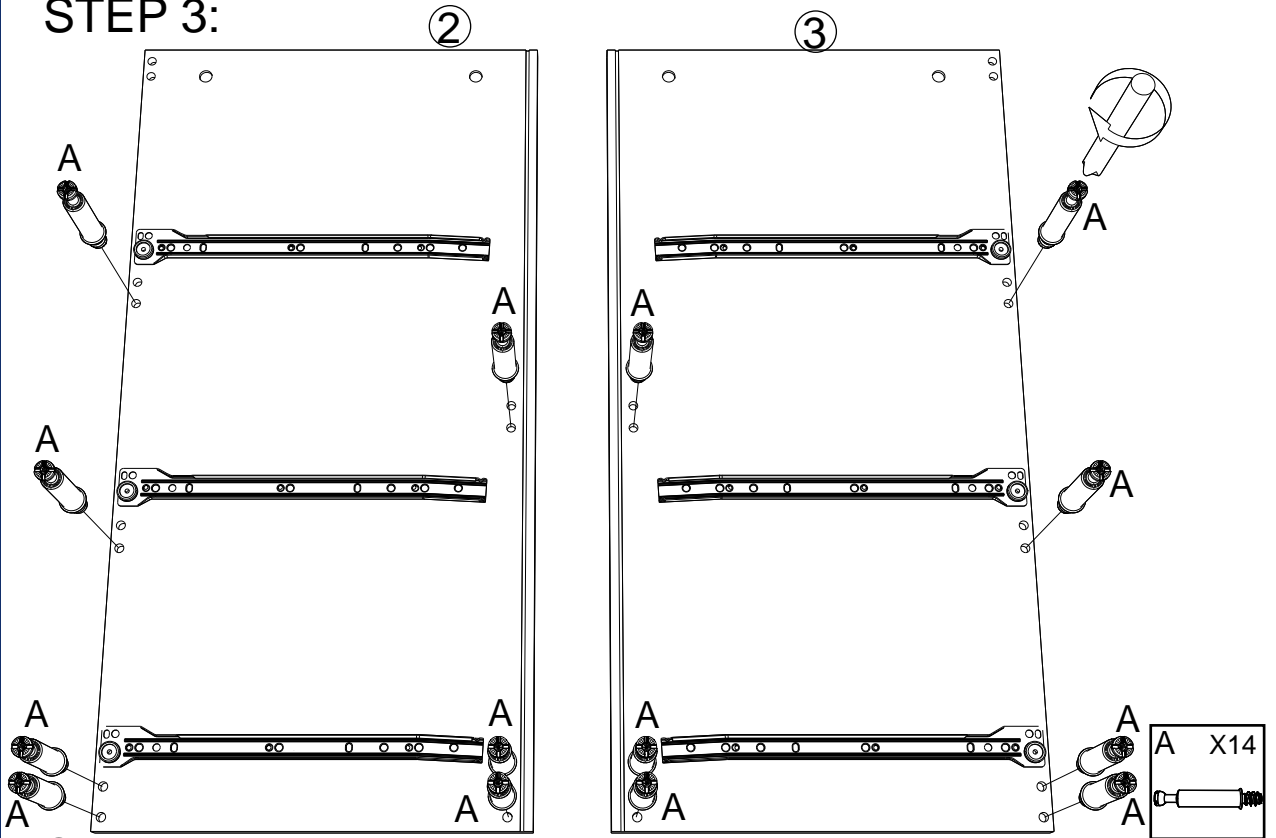

STEP 4:

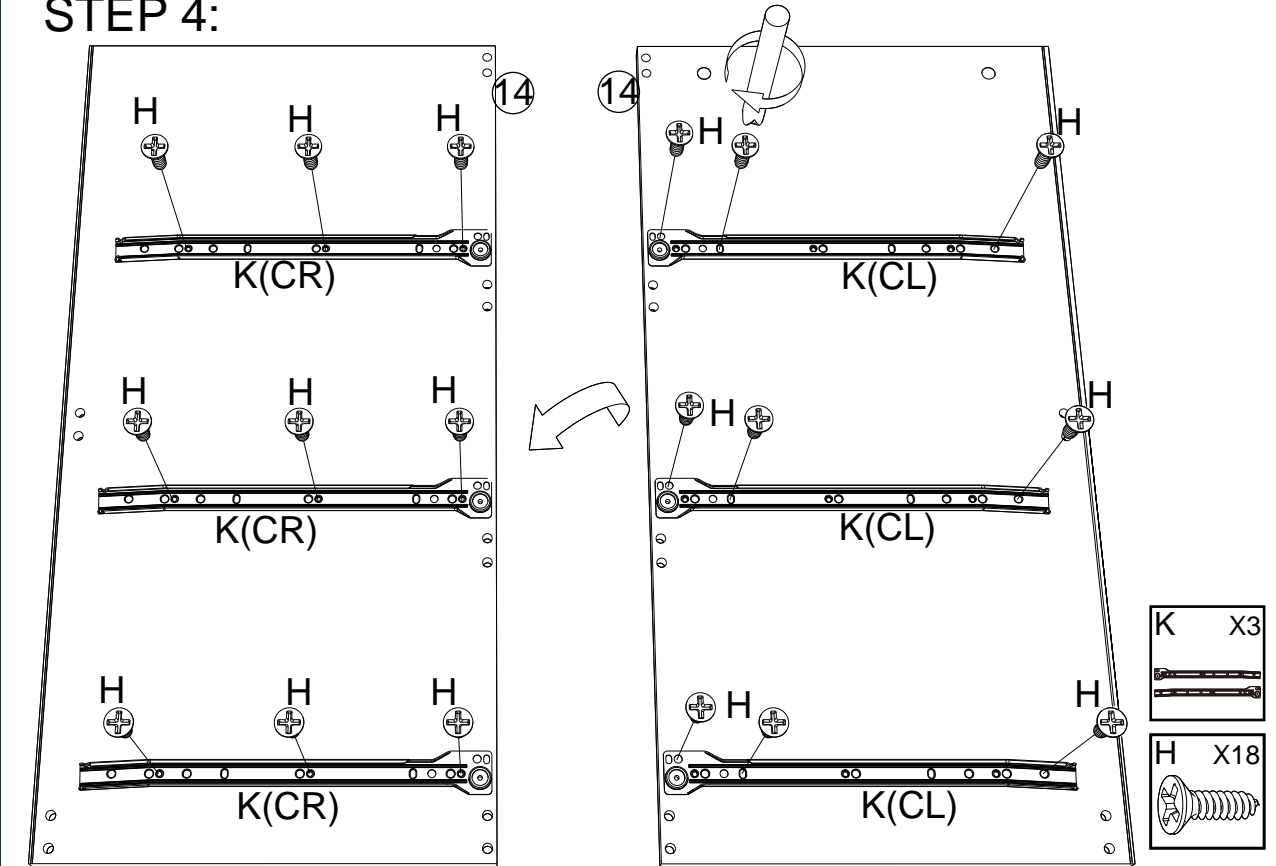

STEP 5:

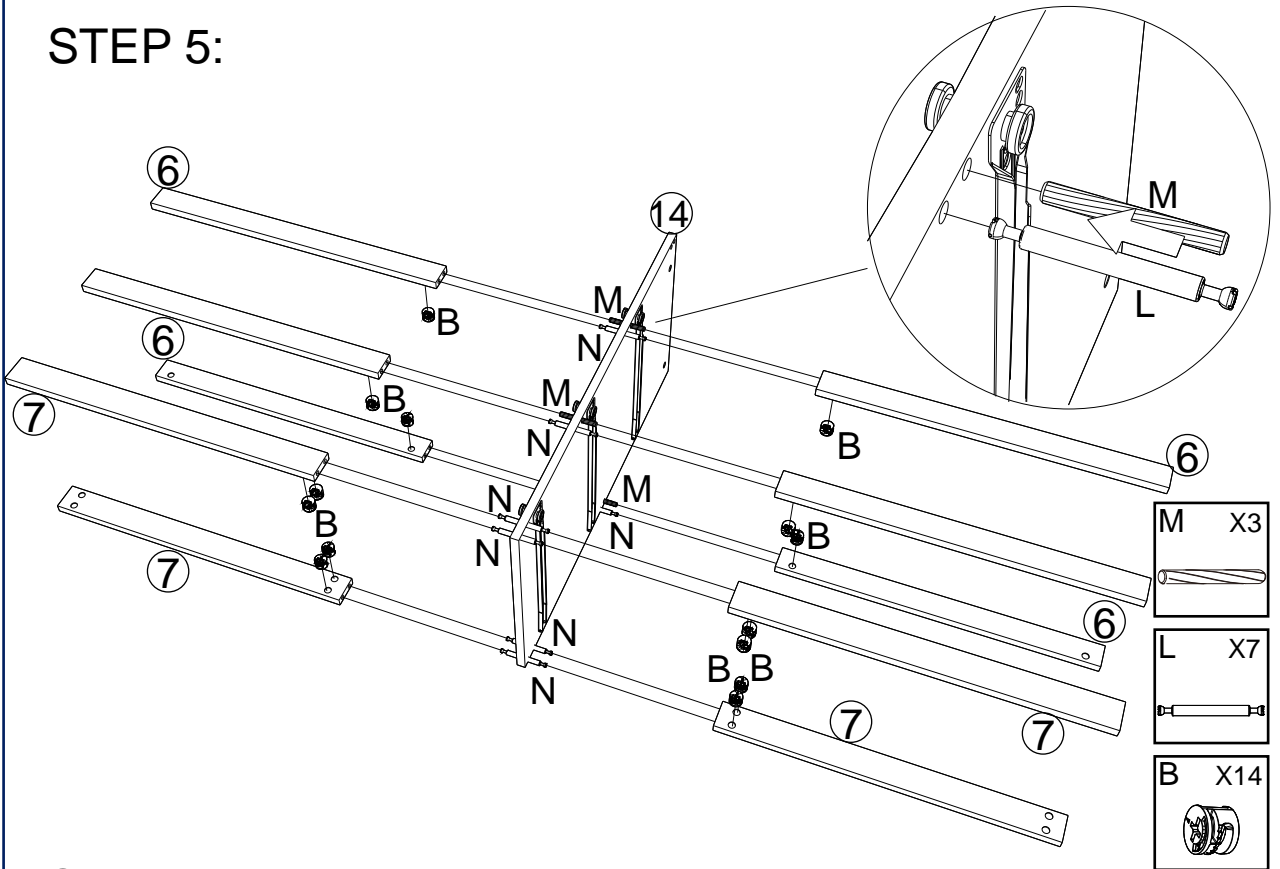

STEP 6:

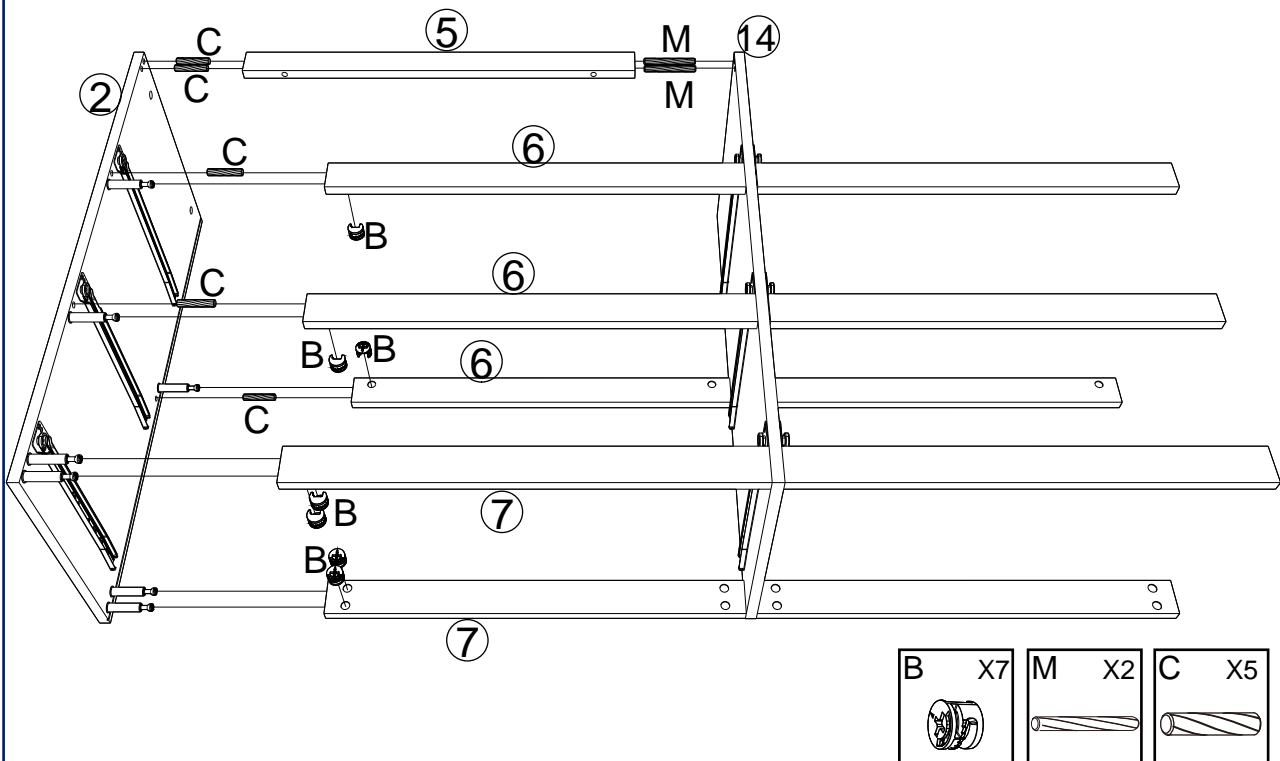

STEP 7:

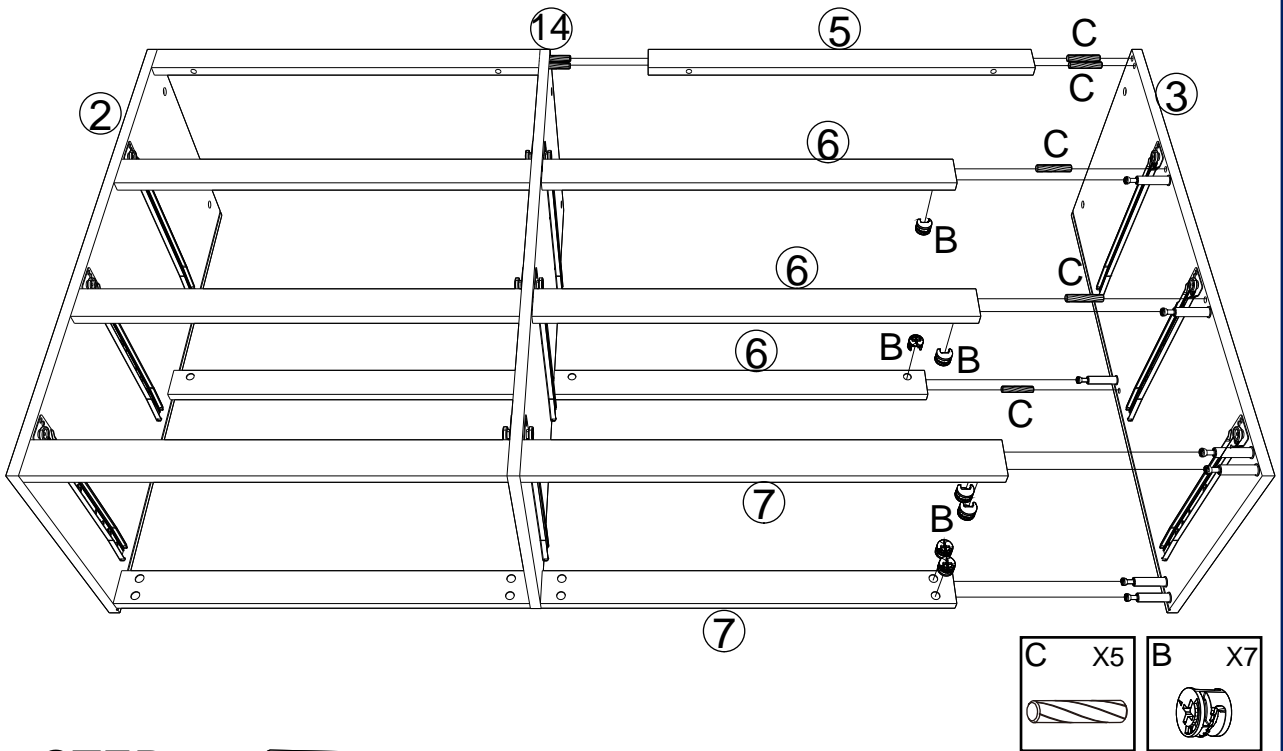

STEP 8:

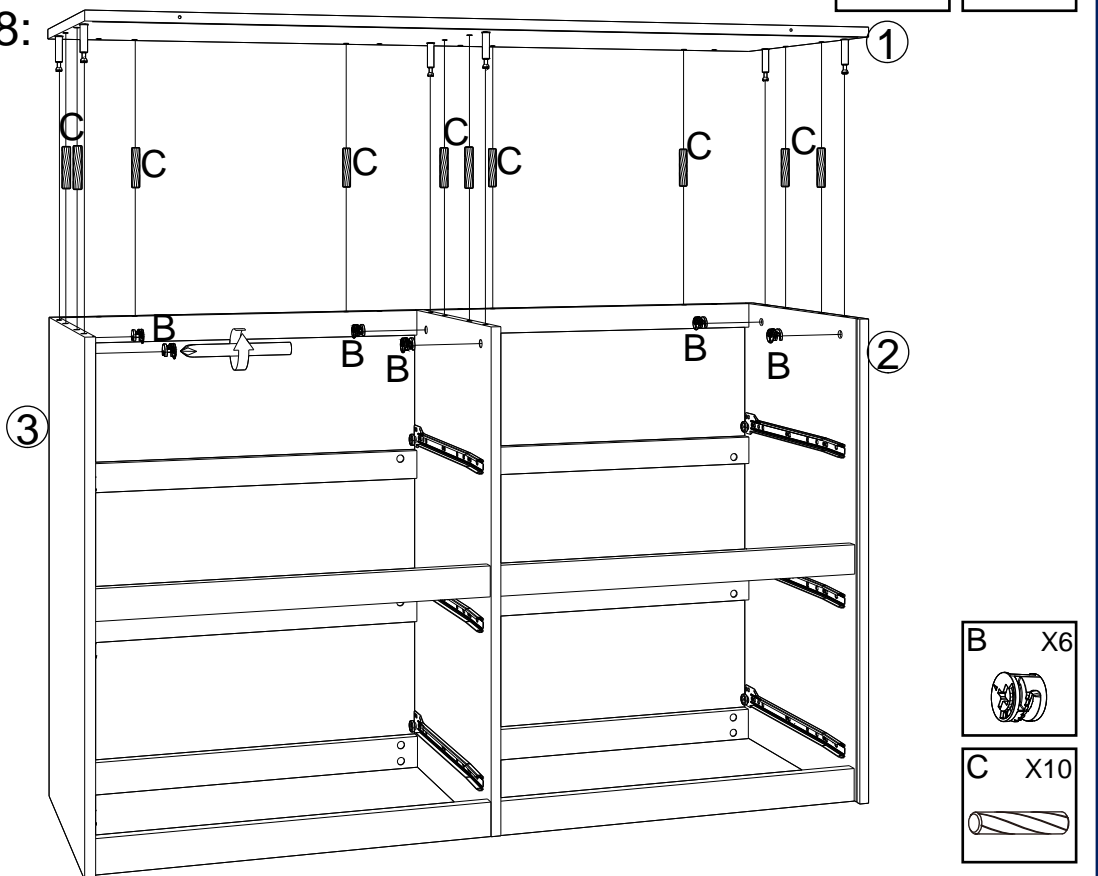

STEP 9:

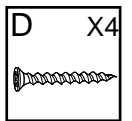
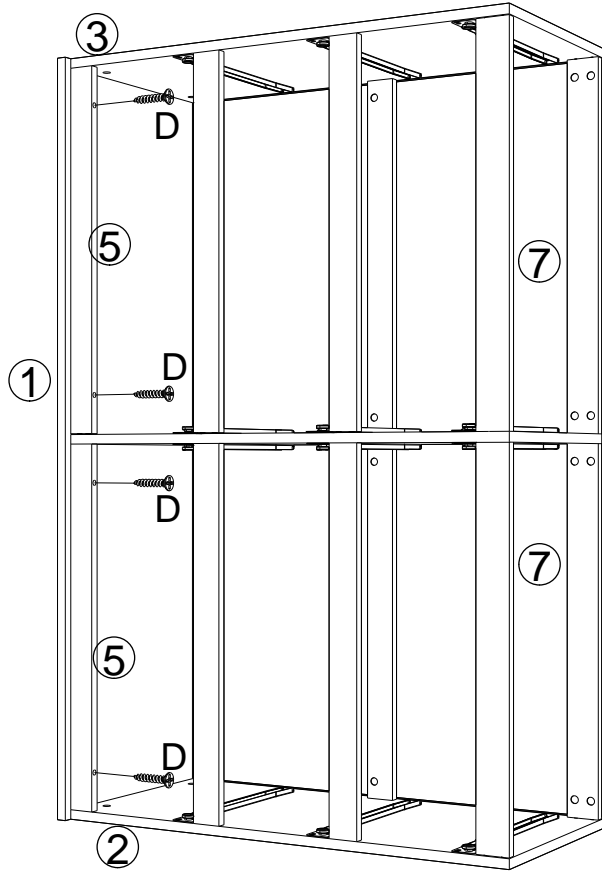

STEP 10:

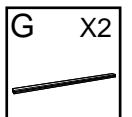
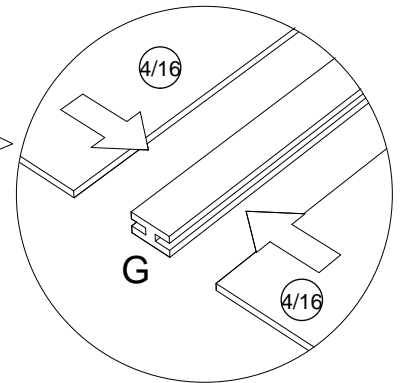
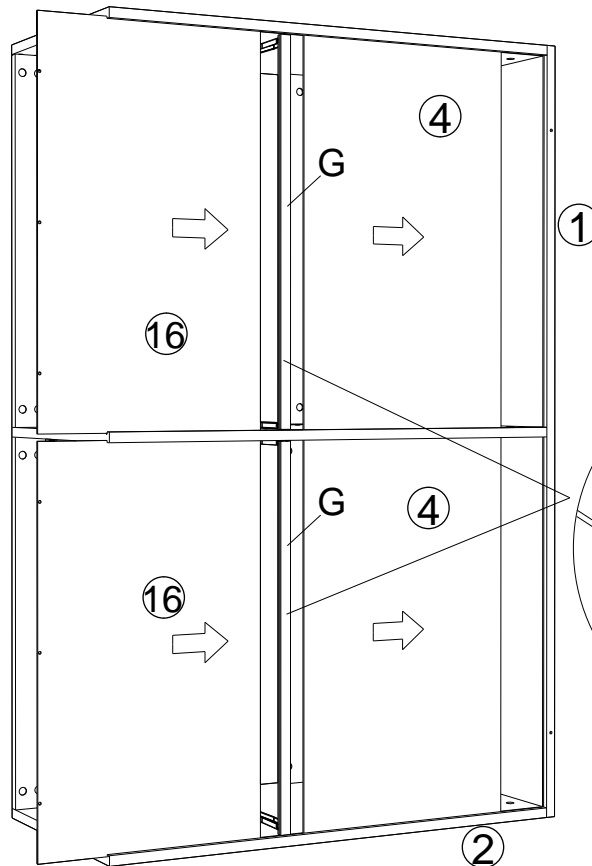

STEP 11:

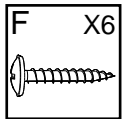
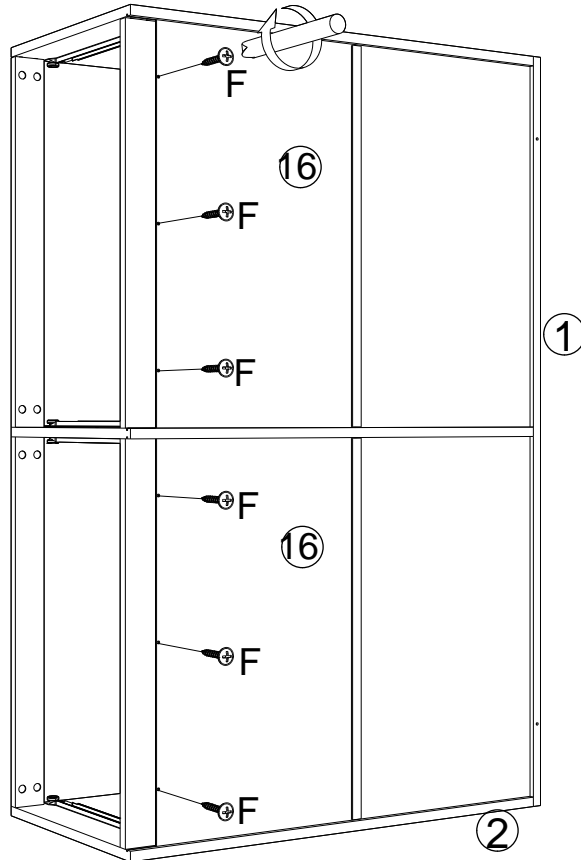

STEP 12:

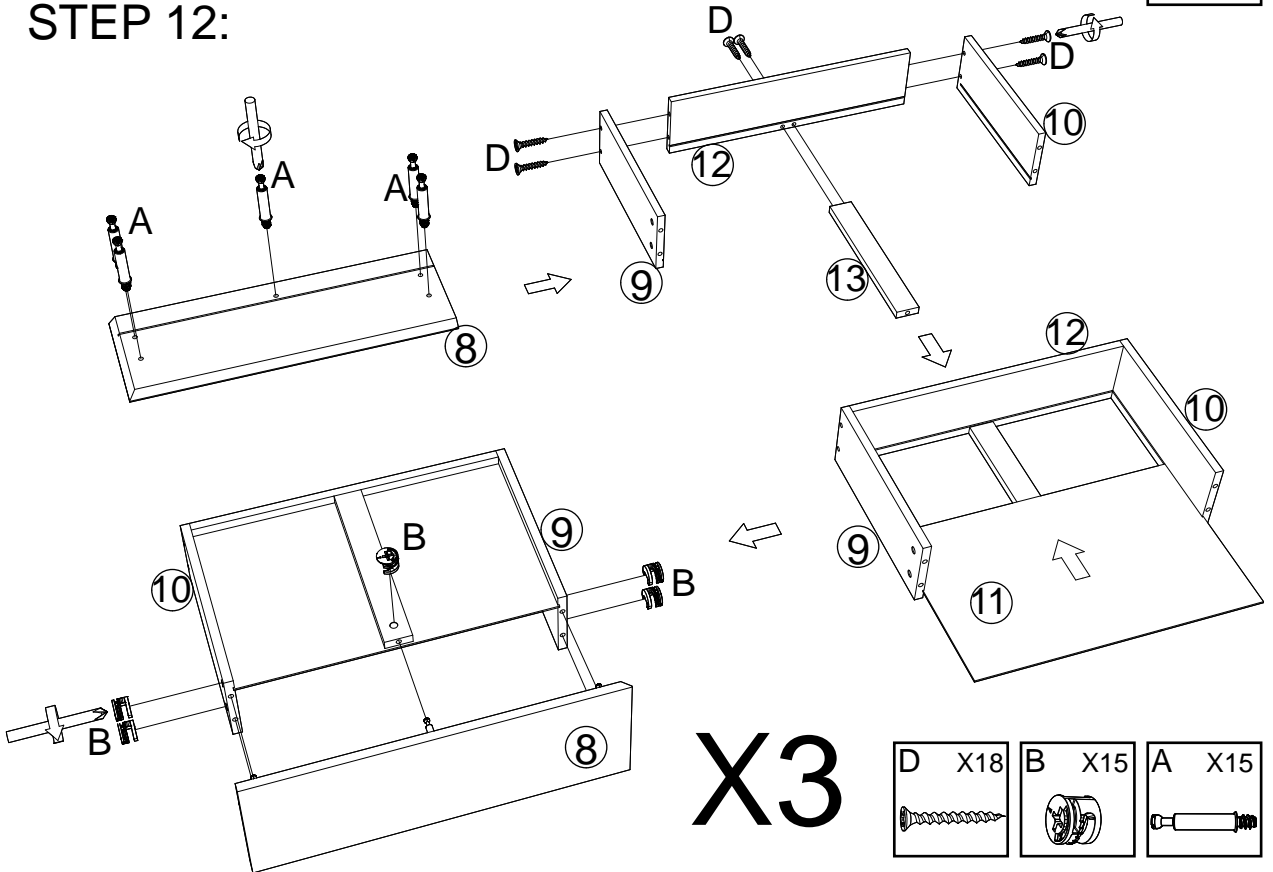

STEP 13:

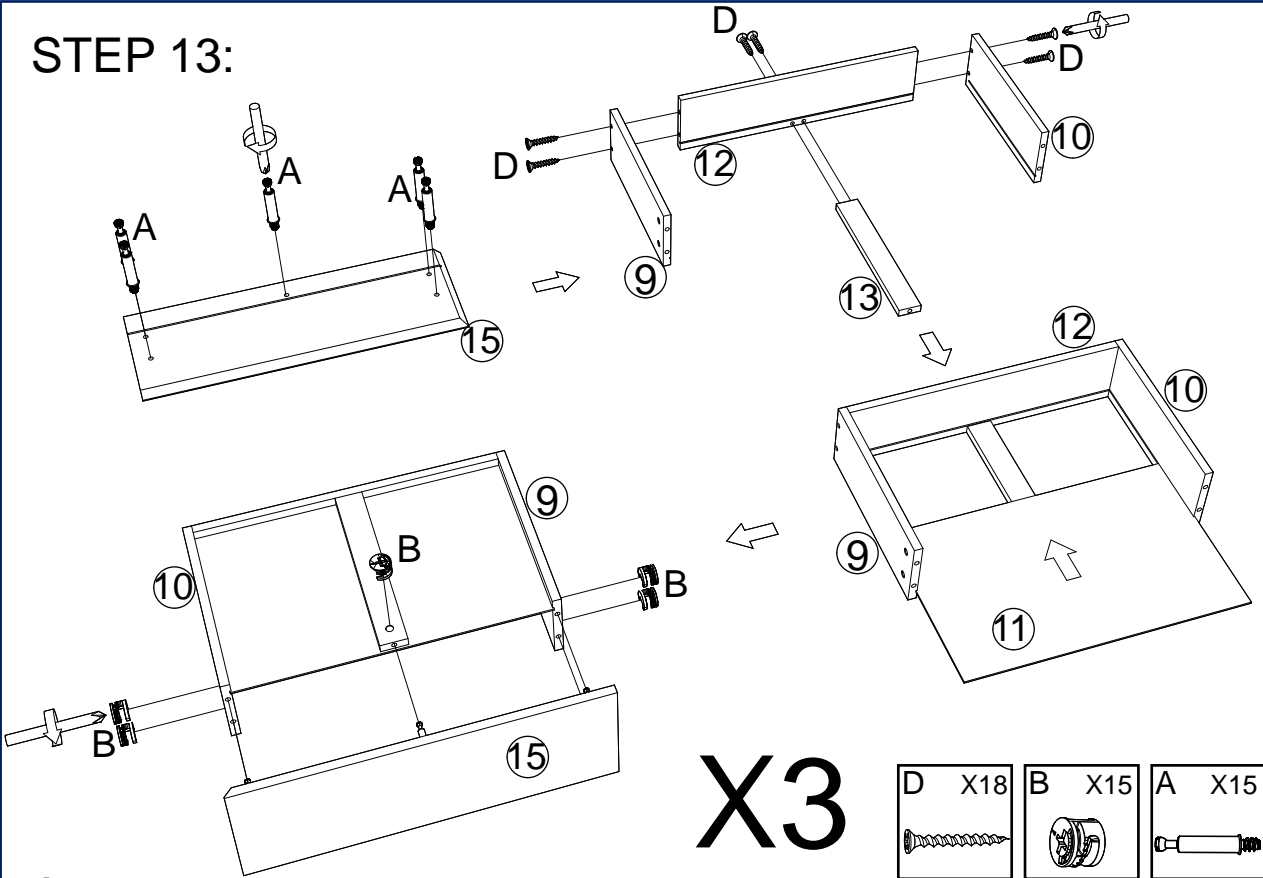

X3

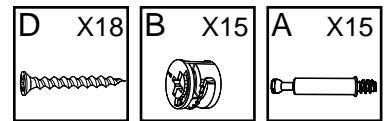

STEP 14:

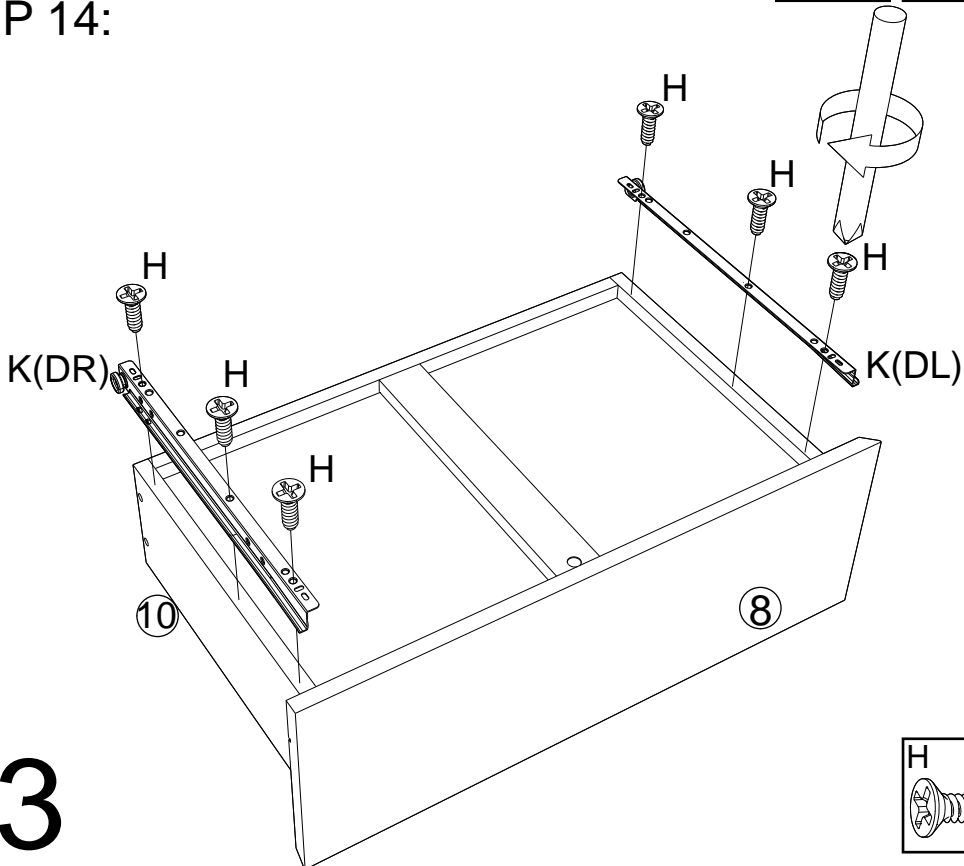

X3

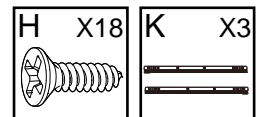

STEP 15:

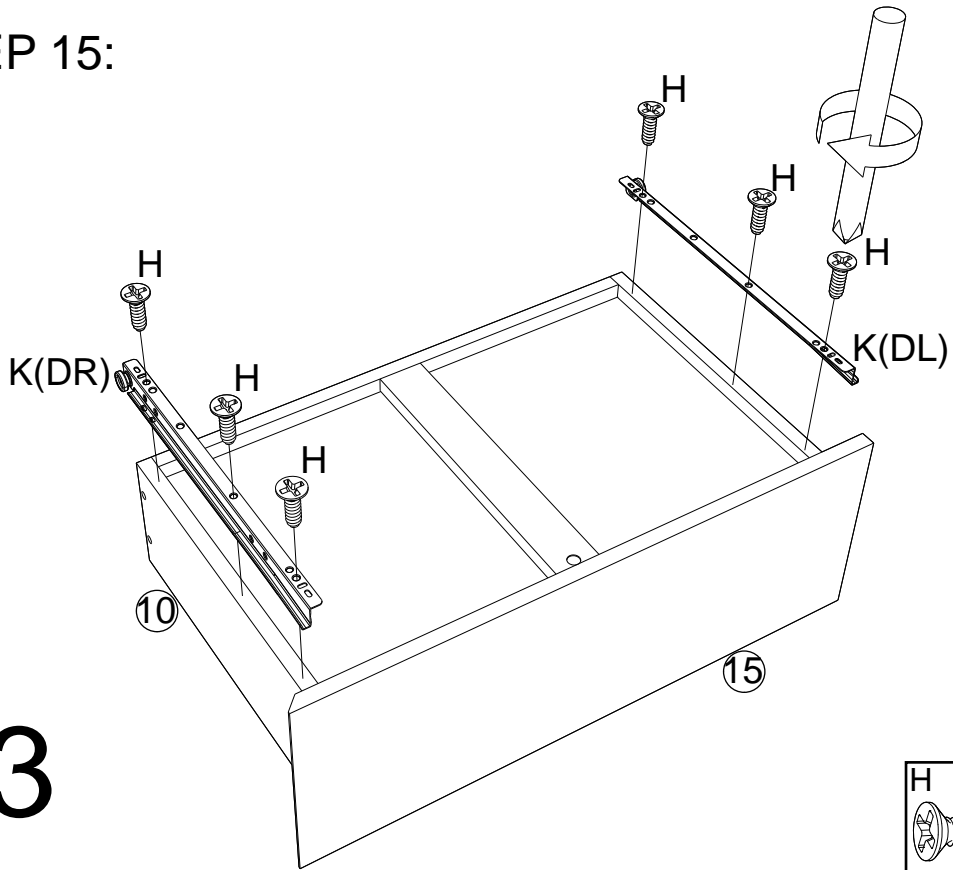

X3

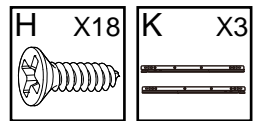

STEP 16:



STEP 17:

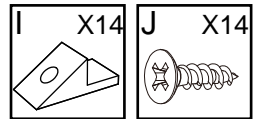
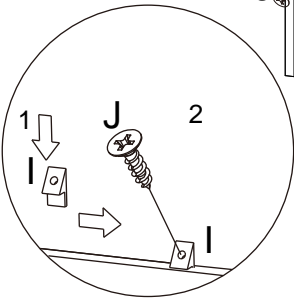
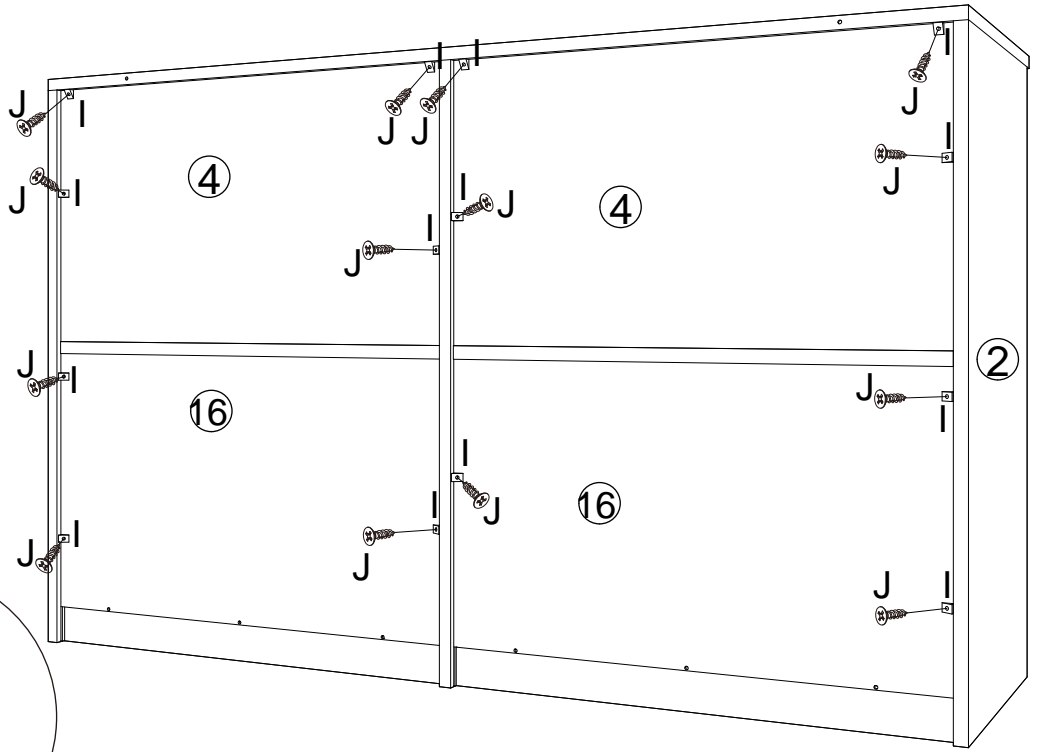

STEP 18: WALL

